

## Next Generation DECT Transceiver Module HW 86012

The optimum embedded wireless solution

DATA  UNWIRED

This next generation DECT module HW 86012, a highly versatile engine for embedded DECT applications, implements the latest technologies while reducing mechanical volume by more than 50 %. Its architecture supplies a full set of useful features for voice and data services in various environments.

The module integrates the complete radio with latest low-IF technology for enhanced performance along with a low-power high performance 16 bit RISC microcontroller for both DECT baseband and application processing.

It can be used in simple point-to-point data or voice applications. Additionally with TCP/IP, PPP and SWAP protocol stacks embedded, it provides powerful means for networking applications, making it a considerable alternative to 802.11 technology.

Interfaces include RS-232 and SPI for serial data, digital PCM and analogue frontend for voice, I<sup>2</sup>C and analogue input/output. General purpose digital I/Os and µC bus interface make the HW 86012 easily expandable.

Optimally suited for data transmission the HW 86012 offers reliable data channels up to 500 kbps.

**DECT:** *The Ideal Wireless Technology* Digital Enhanced Cordless Telecommunications is a highly successful wireless technology. The open DECT standard is accepted in more than 100 countries world-wide. DECT offers competitive advantages for voice and data transmission.

- Exclusive frequency bands eliminate interference
- DECT is free of collisions and congestions
- Co-located DECT systems work together



- Systems are scalable to multi-cell roaming networks
- Up to 64 radio links per base station

### Key Advantages

- TCP/IP, PPP and SWAP protocol stacks onboard
- High speed data transmission paired with low power consumption
- Small footprint for easy integration
- Versatile interfaces for a variety of data and voice applications
- Suited for point-to-multipoint
- Prepared for the future through simple firmware upgrades
- Fully interface compatible to DECT module HW 86010 and WLAN module HW 86050

### Typical Applications

- Wireless LAN replacement
- Serial cable replacement
- Radio networks
- Mobile data acquisition
- Automation and industrial control
- Wireless Local Loop

### Benefits of a Modular Concept

All radio products from Höft & Wessel are based on a modular concept with outstanding advantages:

- Standard modules give best value at lowest price because of volume production
- No initial development costs because of ready-to-use functionality
- Change between DECT and FHSS standards just by plugging-in a different module
- Shorter development cycle, means early time-to-market

Chose from a family of modules the optimum solution for your requirements. The modules are interface compatible and interoperable to equipment following the same radio standard. All radio functions are perfectly encapsulated for the benefit of a much simpler overall design.

### Competent in DECT

Höft & Wessel has been a pioneer in wireless data transmission over DECT and is technology leader in that market. Skilled system engineers continually upgrade and customise the Höft & Wessel communication products for your benefit.

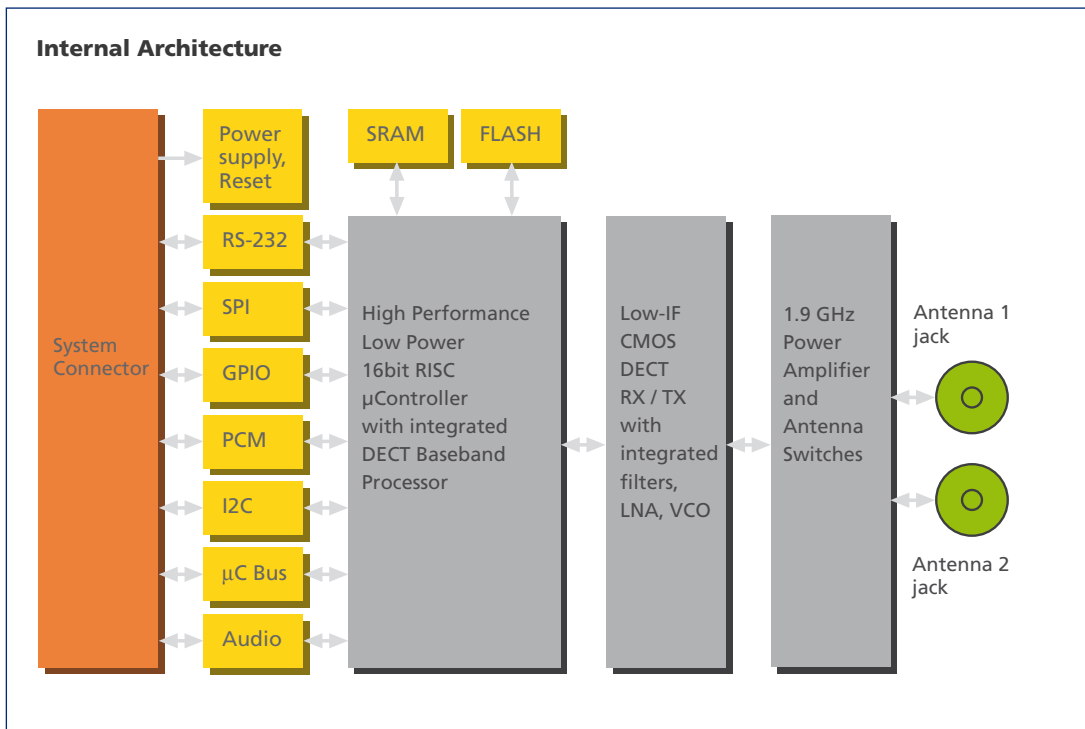

SPECIFICATIONS

<b>Dimensions</b>	Approx. 52 mm x 37 mm x 3,2 mm
<b>Weight</b>	8 g
<b>Temperature range</b>	-20 °C to +60 °C operating
<b>Operating voltage</b>	3.1 V to 3.5 V DC for digital part, 3.0 V to 4.6 V DC for radio frequency part
<b>Modes of Operation</b>	Point-to-point, CLDPS networking with TCP/IP, PPP and SWAP, Configuration mode, Download mode
<b>Overall current consumption</b>	12 mA @ Idle, 70 mA @ 26 kbps, 110 mA @ 115.2 kbps, 300 mA @ 500 kbps
<b>Frequency</b>	1.880 GHz to 1.900 GHz (1.870 GHz to 1.930 GHz optional)
<b>Transmit power</b>	250 mW max.
<b>Receiver sensivity</b>	-93 dBm typ.
<b>Data rate</b>	up to 500 kbps
<b>Standards</b>	EN 300 175 (DECT Common Interface), ETS 300 651 (Data Services DSP C.2)
<b>Certification</b>	EN 301 406 (TBR6 2 nd edition), EN 60 950/2000 (safety), ETS 301 489-6 (EMC)
<b>Approval</b>	ETSI (EU)
<b>Interface</b>	50-pin system interface
<b>Data interface</b>	RS-232, 3.3V, up to 230.4 kbps, RTS/CTS Handshake, SPI, 3.3 V, up to 5 MHz
<b>Modem lead signals</b>	RTS/CTS, DTR/DSR, DCD, RI
<b>I/O interface</b>	General purpose I/O pins
<b>Analogue interface</b>	Microphone, speaker, ringer
<b>Other interfaces</b>	PCM, I <sup>2</sup> C, bus interface
<b>Antenna system</b>	2 miniature coaxial connectors, diversity support
<b>Range</b>	Up to 300 m (outdoor), up to 60 m (indoor)